

CoroMill® 419

Hoge voedingsfrees

Toepassing

- Vlakfreesen met hoge voeding
- Profiefreesen
- Infreesen
- Helicoidaal frezen
- Bewerken van componenten waarbij lange uitsteeklengtes nodig zijn
- Geschikt voor minder krachtige machines en minder stabiele opspanningsinrichtingen
- Voorfreesen tot semi-nafreesen

ISO toepassingsgebied:



Voordelen en kenmerken

- Hoge productiviteit in toepassingen waar een licht snijdende werking is vereist
- Lange standtijd, met name in moeilijk te bewerken materialen
- Sterke en robuuste wisselplaten voor betrouwbare bewerking
- Laag energieverbruik
- Interne koeling op alle frezen maakt nat bewerken mogelijk evenals koelen met perslucht
- Verminderde axiale krachten met een instelhoek van 19° en een positieve axiale hellingshoek

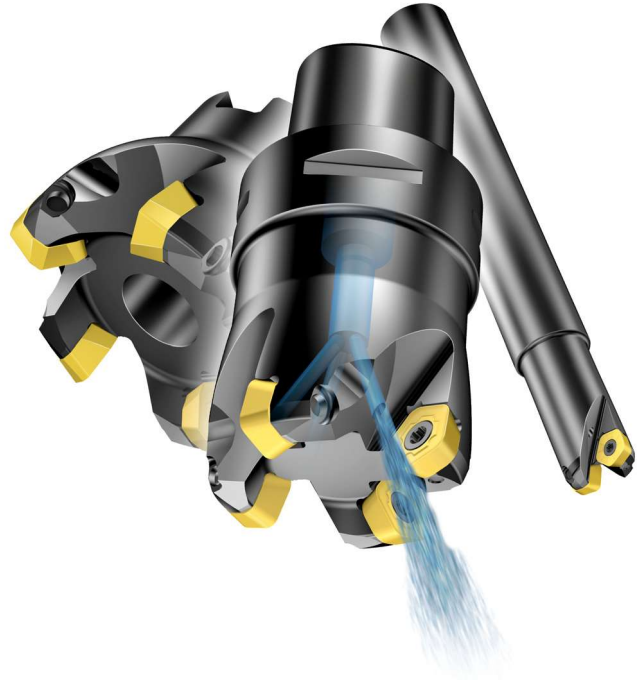

www.sandvik.coromant.com/coromill419

Koppelingen

- Coromant Capto®
- Doorn
- Cilindrische schacht

Wisselplaten

- Vijf snijkanten
- Wisselplaten met parallelle geleiderand voor het vlakfreesen met hoge voeding en radiuswisselplaten voor pocketfreesen
- Uitgebreid programma van hardmetaalsoorten en geometrieën

L



Wijdvertand

M



Dichtvertand

H

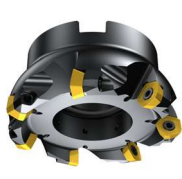

Extra dichtvertand

Vlakfreesen

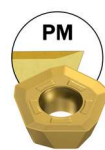

Vlakfreesen en profiefreesen



I29



I31



N6

CoroMill® 419 vlak-en profielfrees

Coromant Capto® - inwendige koelmiddeltoevoer

Hoge voedingsfrees

KAPR

19°

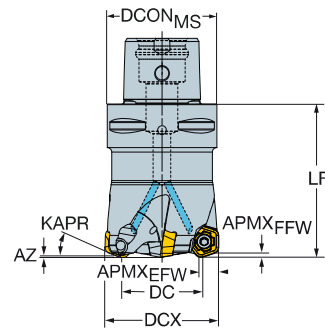
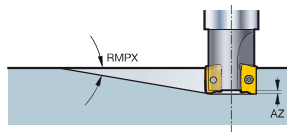

										Afmetingen, mm							
DC	CZCMS	APM _{EFW}	APM _{FFW}	RMPX	AZ	CNSC	CNC		Bestelnummer	DCON _{MS}	DCX	LF	NM	KG	RPMX	CICT	MIID
21.4	14	C3	8.0	2.00	9°	2.0	3	2	419-036C3-14L	32.0	36.0	50.0	5.0	0.36	22400	2	419R-1405
27.4	14	C4	8.0	2.00	8°	2.0	3	3	419-042C4-14M	40.0	42.0	70.0	5.0	0.62	19900	3	419R-1405
37.4	14	C5	8.0	2.00	8°	2.0	3	4	419-052C5-14M	50.0	52.0	70.0	5.0	1.08	17100	4	419R-1405
51.3	14	C6	8.0	2.00	6°	2.0	3	5	419-066C6-14M	63.0	66.0	70.0	5.0	1.73	14600	5	419R-1405
69.3	14	C8	8.0	2.00	5°	2.0	3	6	419-084C8-14H	80.0	84.0	70.0	5.0	3.02	12600	6	419R-1405

Doornbevestiging - inwendige koelvloeistoftoevoer

STDNO
KAPR

ISO 6462
19°

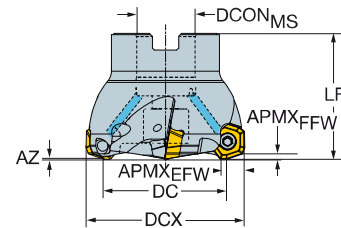
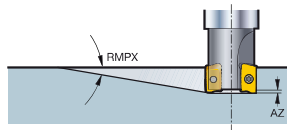

										Afmetingen, mm								
DC	CZCMS	APM _{EFW}	APM _{FFW}	RMPX	AZ	CNSC	CNC		Bestelnummer	DCON _{MS}	ISO	DCX	LF	NM	KG	RPMX	CICT	MIID
29.4	14	16	8.0	2.00	8°	2.0	1	3	419-044Q16-14M	16.0	A	44.0	45.0	5.0	0.37	19300	3	419R-1405
35.4	14	22	8.0	2.00	8°	2.0	1	4	419-050Q22-14M	22.0	A	50.0	45.0	5.0	0.43	17600	4	419R-1405
37.4	14	22	8.0	2.00	8°	2.0	1	5	419-052Q22-14H	22.0	A	52.0	45.0	5.0	0.50	17100	5	419R-1405
39.4	14	22	8.0	2.00	8°	2.0	1	4	419-054Q22-14M	22.0	A	54.0	45.0	5.0	0.47	16800	4	419R-1405
	14	22	8.0	2.00	8°	2.0	1	5	419-054Q22-14H	22.0	A	54.0	45.0	5.0	0.47	16800	5	419R-1405
48.3	14	22	8.0	2.00	7°	2.0	1	4	419-063Q22-14L	22.0	A	63.0	50.0	5.0	0.63	15100	4	419R-1405
	14	22	8.0	2.00	7°	2.0	1	5	419-063Q22-14M	22.0	A	63.0	50.0	5.0	0.58	15100	5	419R-1405
51.3	14	22	8.0	2.00	6°	2.0	1	5	419-066Q22-14M	22.0	A	66.0	50.0	5.0	0.66	14600	5	419R-1405
	14	22	8.0	2.00	6°	2.0	1	6	419-066Q22-14H	22.0	A	66.0	50.0	5.0	0.65	14600	6	419R-1405
65.3	14	27	8.0	2.00	5°	2.0	1	5	419-080Q27-14M	27.0	A	80.0	50.0	5.0	1.07	13000	5	419R-1405
	14	27	8.0	2.00	5°	2.0	1	6	419-080Q27-14H	27.0	A	80.0	50.0	5.0	1.06	13000	6	419R-1405
69.3	14	27	8.0	2.00	5°	2.0	1	6	419-084Q27-14M	27.0	A	84.0	50.0	5.0	1.12	12600	6	419R-1405
	14	27	8.0	2.00	5°	2.0	1	7	419-084Q27-14H	27.0	A	84.0	50.0	5.0	1.15	12600	7	419R-1405
85.3	14	32	8.0	2.00	0°	2.0	1	6	419-100Q32-14M	32.0	B	100.0	50.0	5.0	1.68	11400	6	419R-1405
	14	32	8.0	2.00	0°	2.0	1	7	419-100Q32-14H	32.0	B	100.0	50.0	5.0	1.69	11400	7	419R-1405

Reserve onderdelen
Wisselplaat-schroef
5513 020-78

Ga voor de complete lijst van reserveonderdelen naar www.sandvik.coromant.com



I31



L2



M1



N23



N6



N9



N15

CoroMill® 419 vlak-en profielfrees

Cilindrische schacht - interne koelmiddeltoevoer

Hoge voedingsfrees

KAPR

19°

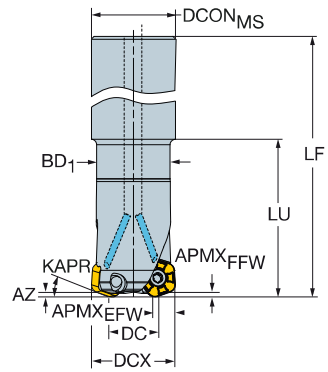
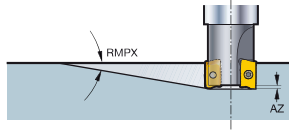

Afmetingen, mm

DC	CZC _{MS}	APM _{EFW}	APM _{FFW}	RMPX	AZ	CNSC	Bestelnummer	DCON _{MS}	DCX	BD	LB	LF	LU	NM	KG	RPMX	CICT	MIID	
17,4	14	32	8,0	2,00	10°	1	2	419-032A32L-14L	32,0	32,0	28,0	57,0	250,0	60,0	5,0	1,40	24700	2	419R-1405
25,4	14	32	8,0	2,00	8°	1	3	419-040A32L-14M	32,0	40,0	28,0		250,0		5,0	1,50	20600	3	419R-1405

Reserve onderdelen
Wisselplaat-schroef
5513 020-78

Ga voor de complete lijst van reserveonderdelen naar www.sandvik.coromant.com



I31



L2



N23



N6



N9



N15

CoroMill® 419 freeswisselplaat

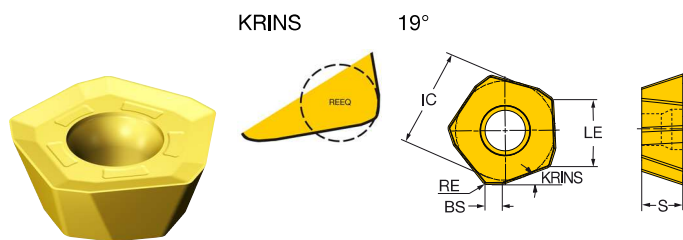

		RE	Bestelnummer	P		M		K		N		S		H		Afmetingen, mm					
				1130	4220	4330	4340	1040	1130	2040	1020	3040	3330	1130	S30T	S40T	1010	1130	IC	LE	s
Middelmatig	MM	14	0.80	419R-1405E-MM	★	★	★	☆	☆			☆	☆	★	☆	☆	13.5	9.0	5.47	2.0	4.50
	PM	14	0.80	419R-1405M-PM	★	☆	★	☆	★	☆	★	☆	★	☆	☆	☆	13.5	9.0	5.47	2.0	4.50
	SM	14	3.00	419N-140530E-SM	★	★	★	★	☆	☆			☆	★	☆	☆	13.5	9.0	5.47		4.50
Zwaar	KH	14	3.00	419N-140530M-KH		☆	★			☆	★	★					13.5	9.0	5.47		4.50
	PH	14	0.80	419R-1405M-PH			☆	★			★				★		13.5	9.0	5.47	2.0	4.50



I29



I154



I175



N23



N10

